



ARENA CONDITIONER 62-118

Made in Germany

The Professional Maintenance Tool
for leveling, loosening, mixing and grading all kinds of
equestrian riding surfaces.

Operation and maintenance instructions for
models with working widths of 62" - 118"

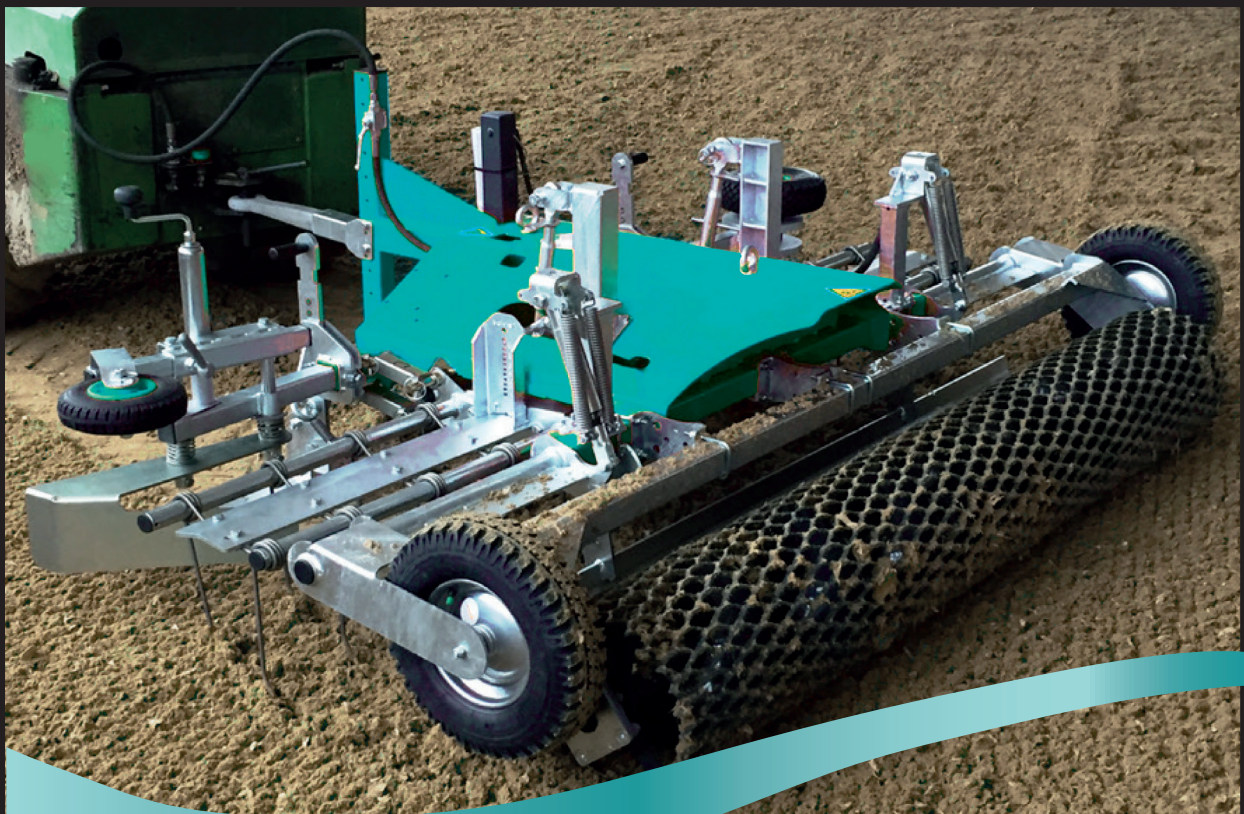

Caution! Safety information!

Safety precautions

- Please do not stand next to the Arena Conditioner during operation.
- Riding on the device is strictly prohibited.
- Caution: nearing the swing area of the Arena Conditioner is prohibited-fatal!
- When leaving the tractor, the device must be lowered.

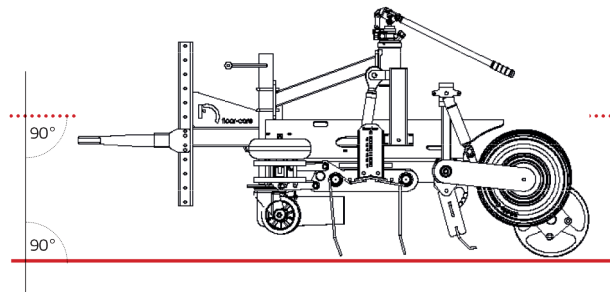

Important reference!

Arena Conditioner undercarriage and/or digging device must be retracted during setting and use. The undercarriage should be used only for parking of the leveler.

Attach Arena Conditioner to pulling equipment by either 3 point or ball hitch. Making sure the unit is level. Use attached leveling circle on Arena Conditioner hood.

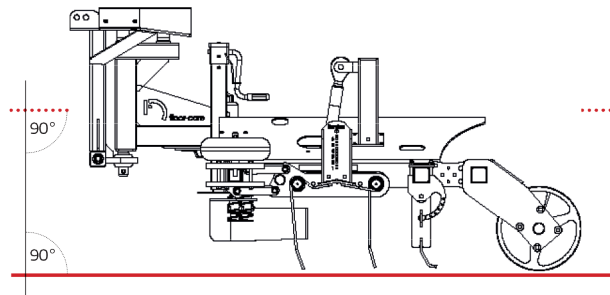

- Adjusting the turnbuckle left or right will raise the tines up or down.
- Before adjusting the tines you have to make sure that the self-locking-nuts are loosened and tightened again after adjustment has been made.
- Important is that both clamping screws are screwed in or out equally.

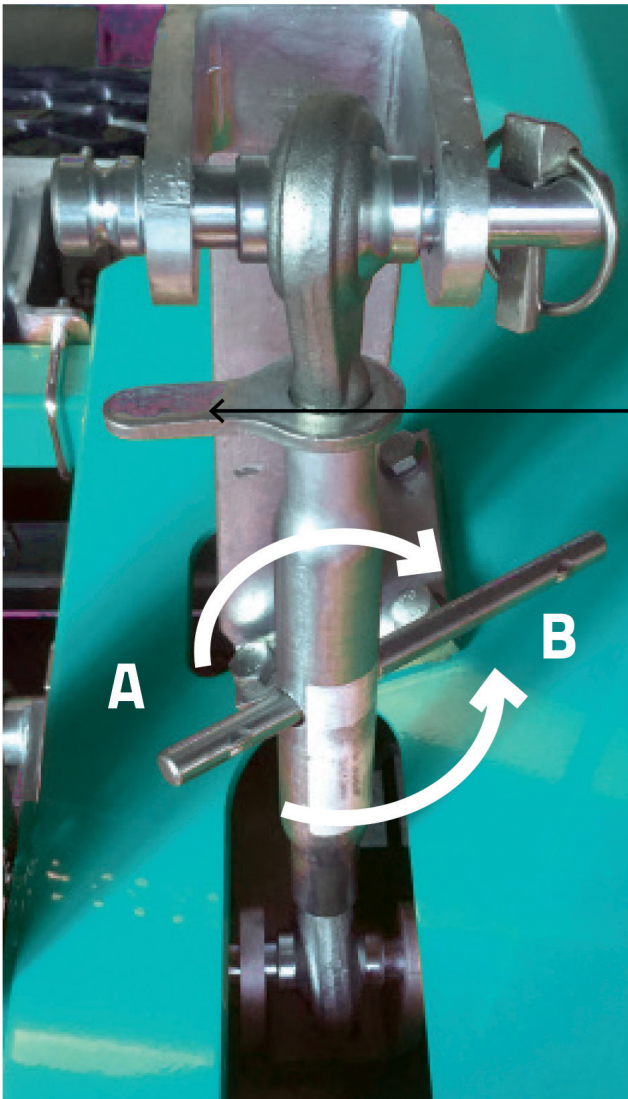

Caution! After adjustment please tighten the clamping screw again.

By twisting the turnbuckle towards A the depth of the tines will be reduced. Twisting the turnbuckle towards B the depth of the tines will be maximized.

Use and handling of the Arena Conditioner in conjunction with the guide wheel.

Guide wheel can be adjusted in and out by loosening the locking pin. Once loose, slide guide wheel to desired position and tighten locking pin back down.

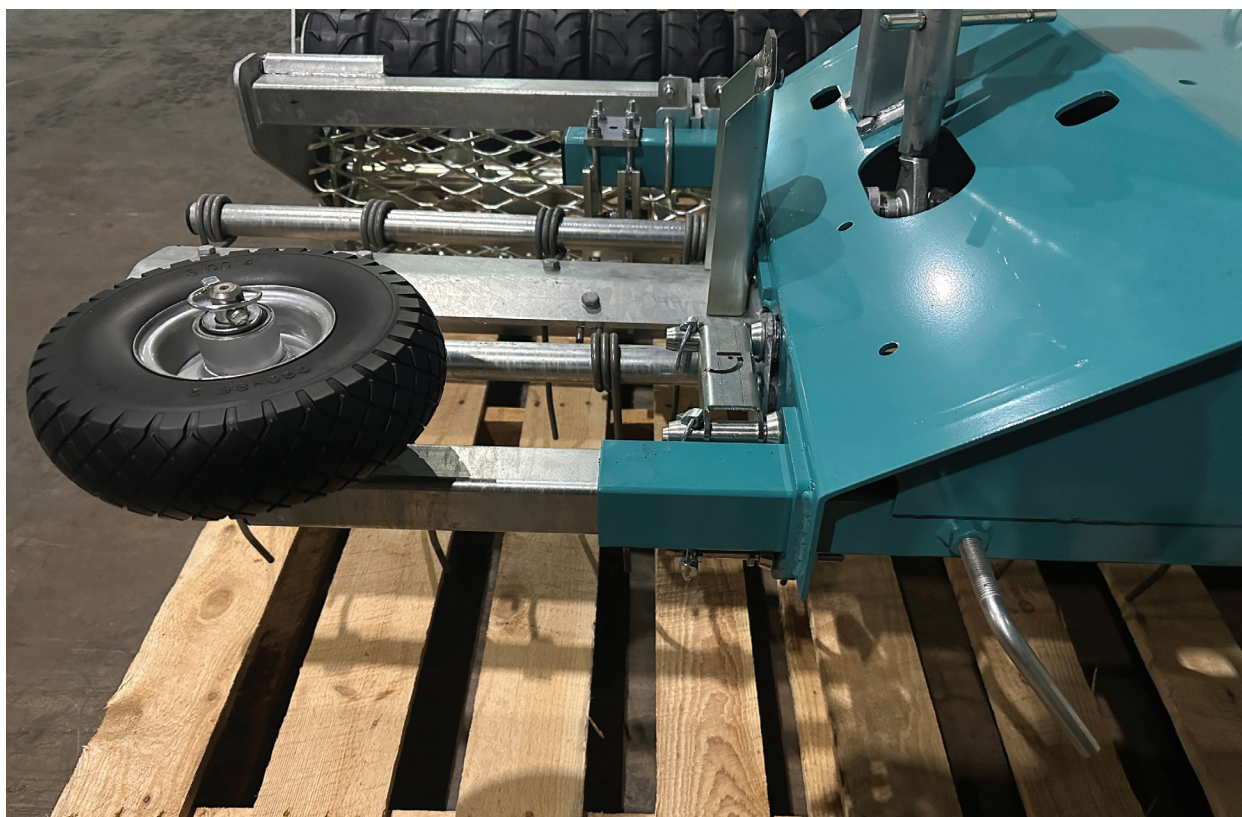

Instructions for the maintenance and lubrication of the Arena Conditioner for riding arena care.

Regular care and maintenance increase the life span of the device and improve the working quality of the Arena Conditioner.

- regular washing is important for the device and improves maintenance
- every 25 working hours you have to lubricate all with **1** marked points
- maintenance of groomers with swivel heads.
PLEASE REMOVE THE PROTCTIVE COVER MARKED WITH **NUMBER 2**,
Remove the cotter pin, wear sleeve and grease the #2 pin as shown.
- Please inspect all parts and grease inlets visually every 12 weeks.

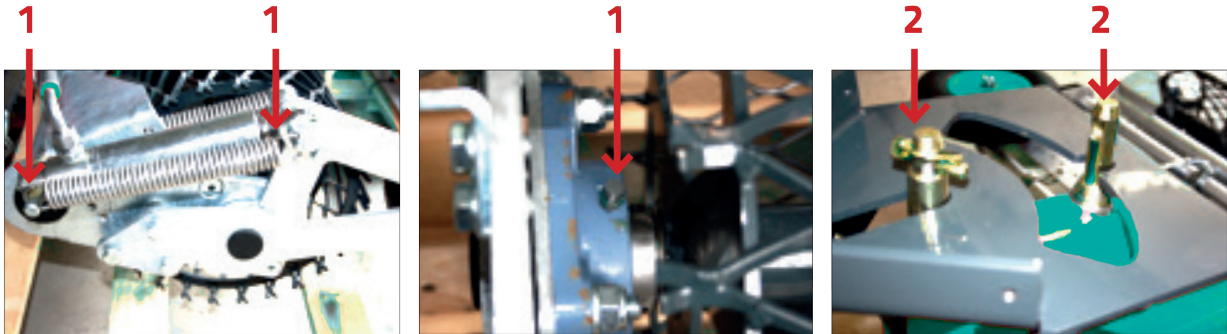

Notes:

The Driving Speed:

You will need to adapt to the driving speed, so that the **Arena Conditioner** can smooth any unevenness from the soil. Do not drive too fast, as the blade cannot be deposited in the soil effectively and unevenness can not be graded.

The perfect speed is between 3 and 7 miles per hour. On wet surfaces you should drive 7 miles per hour and on dry surfaces slower.

Please note that the spring steel tines need an ideal speed to complete the job effectively. If not achieved the tines will start to whisk.

The Driving Directions:

The driving direction is also important, so that the ground will not be uneven. If the soil is not uneven, you will drive as following: Start driving at the outside lines two times. Then turn towards the inner lines along the long side as wide as one track would be. If the ground is higher outside, you can push it back with the **Arena Conditioner** to the inner side, when driving along the short side.

To grade waves in the ground you need to drive in spiral forms, as shown in picture no. 3.

Attention: Always start with driving along the lines outside as it is shown in picture 1. When driving long circles and round pens, drive ellipse ways regularly.

1.

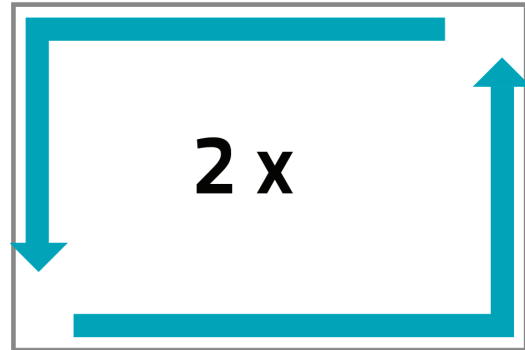

2.

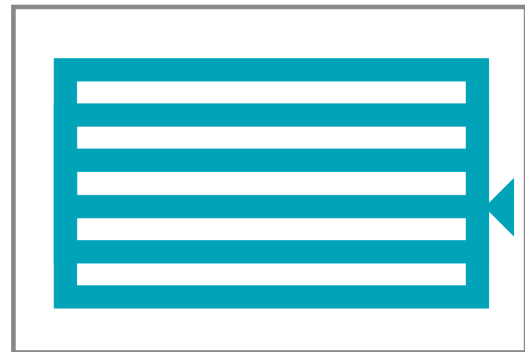

3.

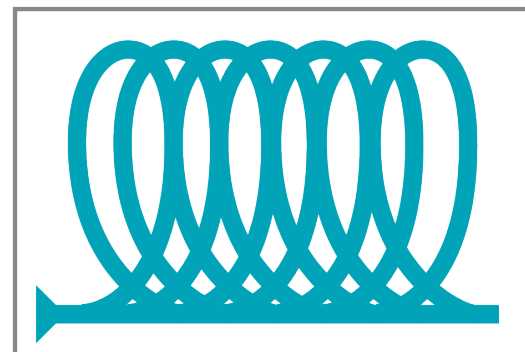

Spare parts list Arena Conditioner 62 -118

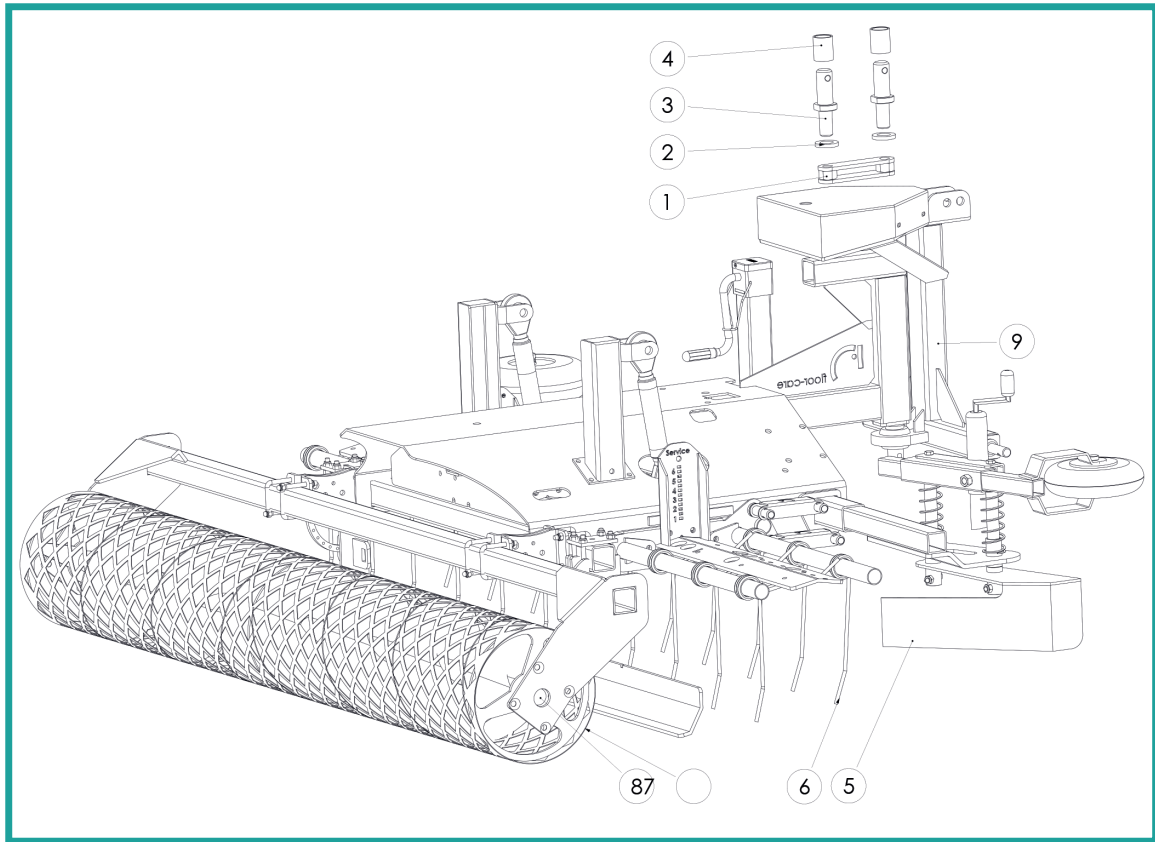

Pos.	Quantity	No. Type	Designation
1	1	G010-0059	holder
2	2	43 / 54	ring
3	2	007-0023	bolt M30
4	2	016-0010	shell
5	1	G006-0009	pusher
6		013-_____	spring steel tines
7	1	Breite	roller
8	2	UCF 208	bearing
9	1	G001-0107	tracking syst.

Spare parts list Arena Conditioner 62 -118

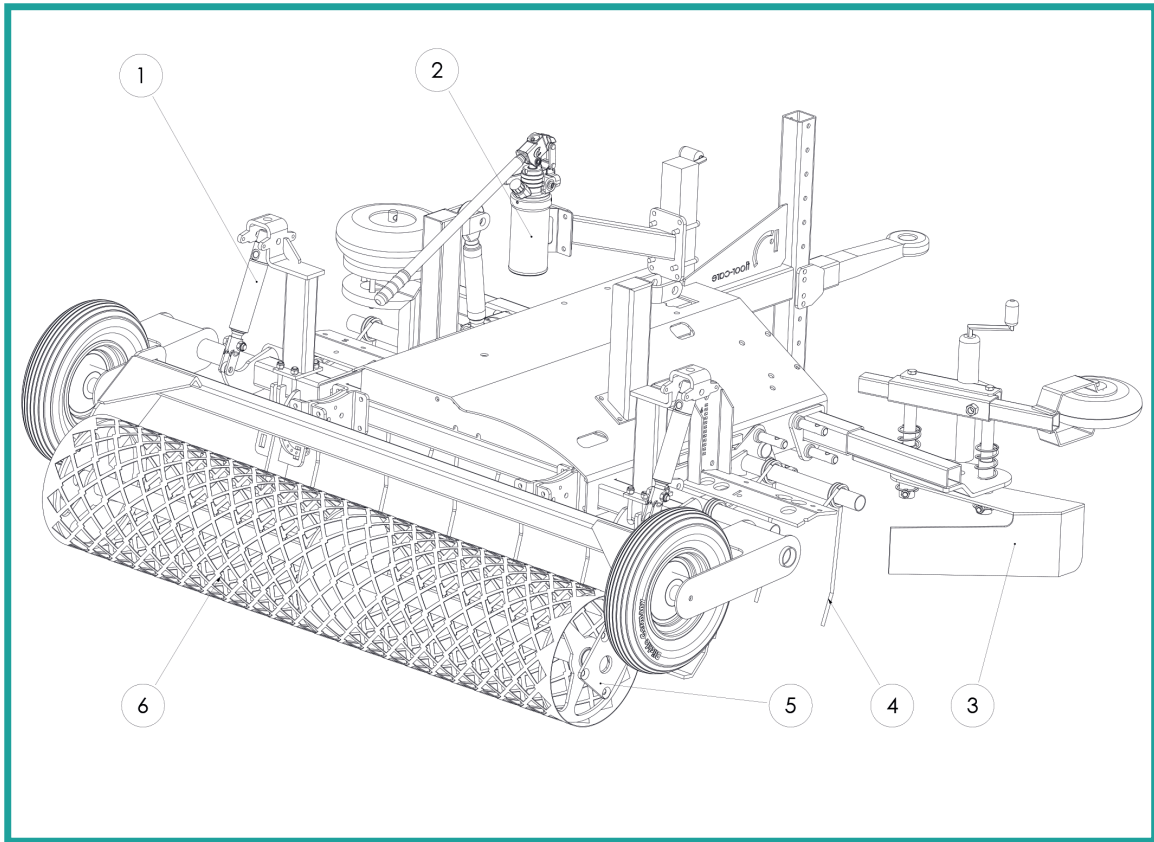

Pos.	Quantity	No. Type	Designation
1	2	4302 / CH-625F/110	hydraulic cylinder
2	1	4936 / CH-P16/SE	hydraulic pump
3	1	G006-0009	pusher
4	_____	013-_____	spring steel tines
5	2	UCF 208	bearing
6	1	013-0014	roller

Spare parts list Arena Conditioner 62 -118

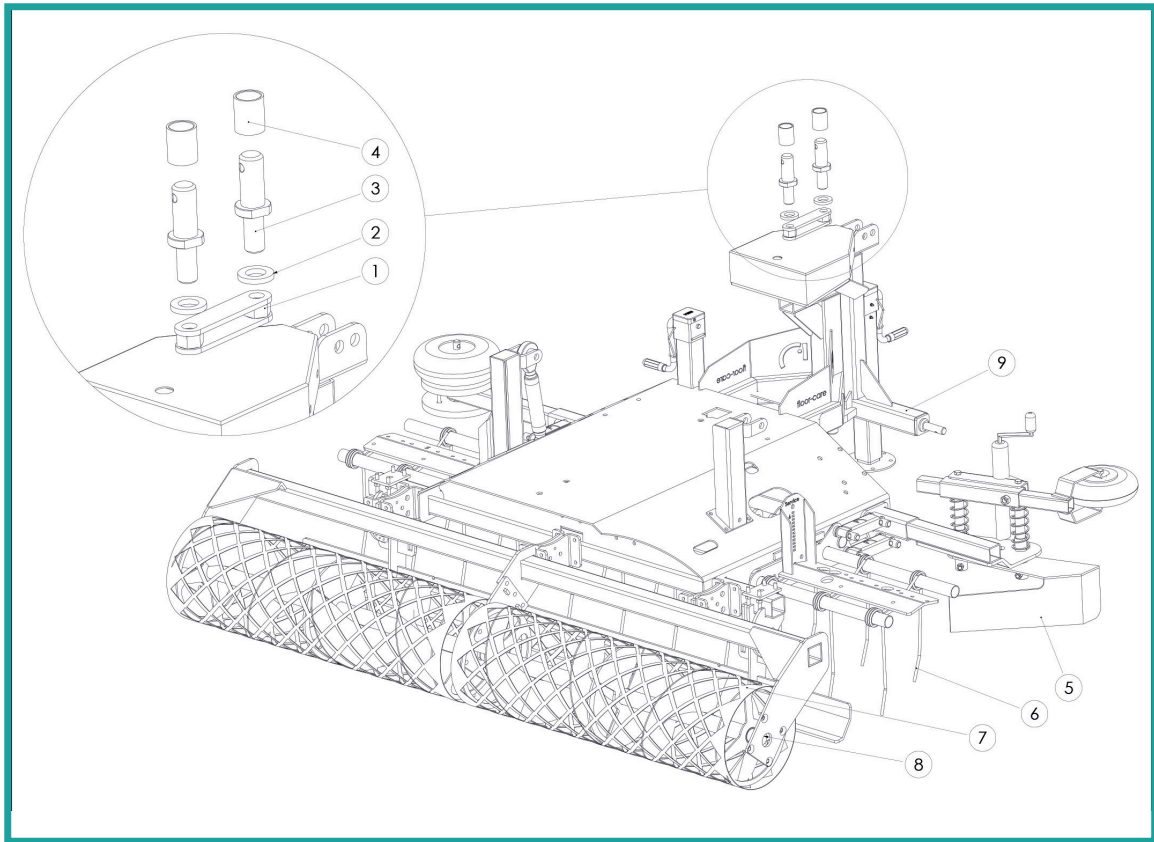

Pos.	Quantity	No. Type	Designation
1	1	G010-0059	holder
2	2	43 / 54	ring
3	2	007-0023	bolt M30
4	2	016-0010	shell
5	1	G006-0009	pusher
6		013-_____	spring steel tines
7	1	Breite	roller
8	2	UCF 208	bearing
9	1	G001-0107	tracking syst.



Polysols, Inc.
851 Simuel Road
Spartanburg, SC 29301 USA

Call: (864) 579-4484

www.ggtfooting.com
Email: ggt-footing@polysols.com

Visit Our Website



Watch Groomer
Videos On
Our Website

Follow Us Online

